

Technical information

SCW+ curtain wall system



SENIOR **ALUMINIUM** SYSTEMS™

Scope

The SCW+ curtain wall system has been designed with enhanced thermal performance and to meet current building regulations. It is semi unitised, zone drained and pressure equalized and offers a slim 50mm sightline, with a choice of 3 mullion and 4 transom depths. The system is capable of being fabricated into ladders for quick assembly on site and can accept a variety of glazing types. Other profiles can be incorporated giving flexibility of design.

Materials

- All aluminium sections are extruded using Aluminium Alloy 6060 or 6063 T6 to BS EN 755 part 9 2008.
- Polyamide thermal barriers are manufactured in accordance with PA66 GF25.
- Gaskets are manufactured in accordance with BS3734.

Finishes

SCW+ curtain wall sections are available typically in 3 finishes.

- Polyester Powder Coating to BS EN 12206: 2004 Part 1 - painted in house in single or dual colour, and surface finish at 40 microns standard, or enhanced to 60 microns for marine environments, in accordance with ISO9001, ISO14001 and ISO18001.
- Anodised and Anolok finishes are to BS3897: 1991 to a minimum of 25 microns (AA25), supplied in either satin or polished finish in a limited range of colours.
- Mill finish.

Construction

SCW+ framing is constructed using mechanical methods at butt joints, assembling using stainless steel self-tapping screws into integral screw ports extruded into the body of the sections, directly through square cut adjoining component parts. A proprietary sealant is used on all metal to metal joints and gasket to gasket joints during assembly in line with good practice.

Vertical sections are designed to run through which enables individual panels to be made separately and assembled on site for large or multi-panel frames.

Optional shear blocks are available for joint and sectional re-inforcing or expansion joints and larger spans, over 1200mm

Weather Rating

CWCT Sequence B

Air Permeability	600 Pa
Water Tightness	600 Pa
Wind Resistance	2400 Pa

EN13830:2003

Air Permeability	600 Pa
Water Tightness	600 Pa
Wind Resistance	2400 Pa

Glazing

Thickness	6mm	to	28mm
-----------	-----	----	------

Average U Values

Due to the variety of profiles, mullion spacings, glass and panel specifications on each project; a specific U-value calculation will be required. Please contact our Technical Department or Architectural Advisors.

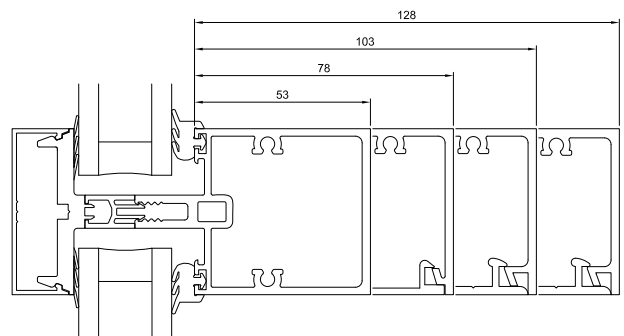

Environmental

Senior Architectural Systems is fully compliant with BS EN ISO19001, BS EN ISO 14001 and OHSAS 18001 Standards.

SCW+ when used on projects involved in a BREEAM assessment, or within the Code for the Sustainable Built Environment and the Code for Sustainable Homes (which therefore involves the Green Guide to specification) can offer significant benefits.

Specification. Please contact our national team of architectural advisors for advice on product suitability, calculations and NBS or bespoke specifications.